

Pedestrian Speed Gates

Access control solutions

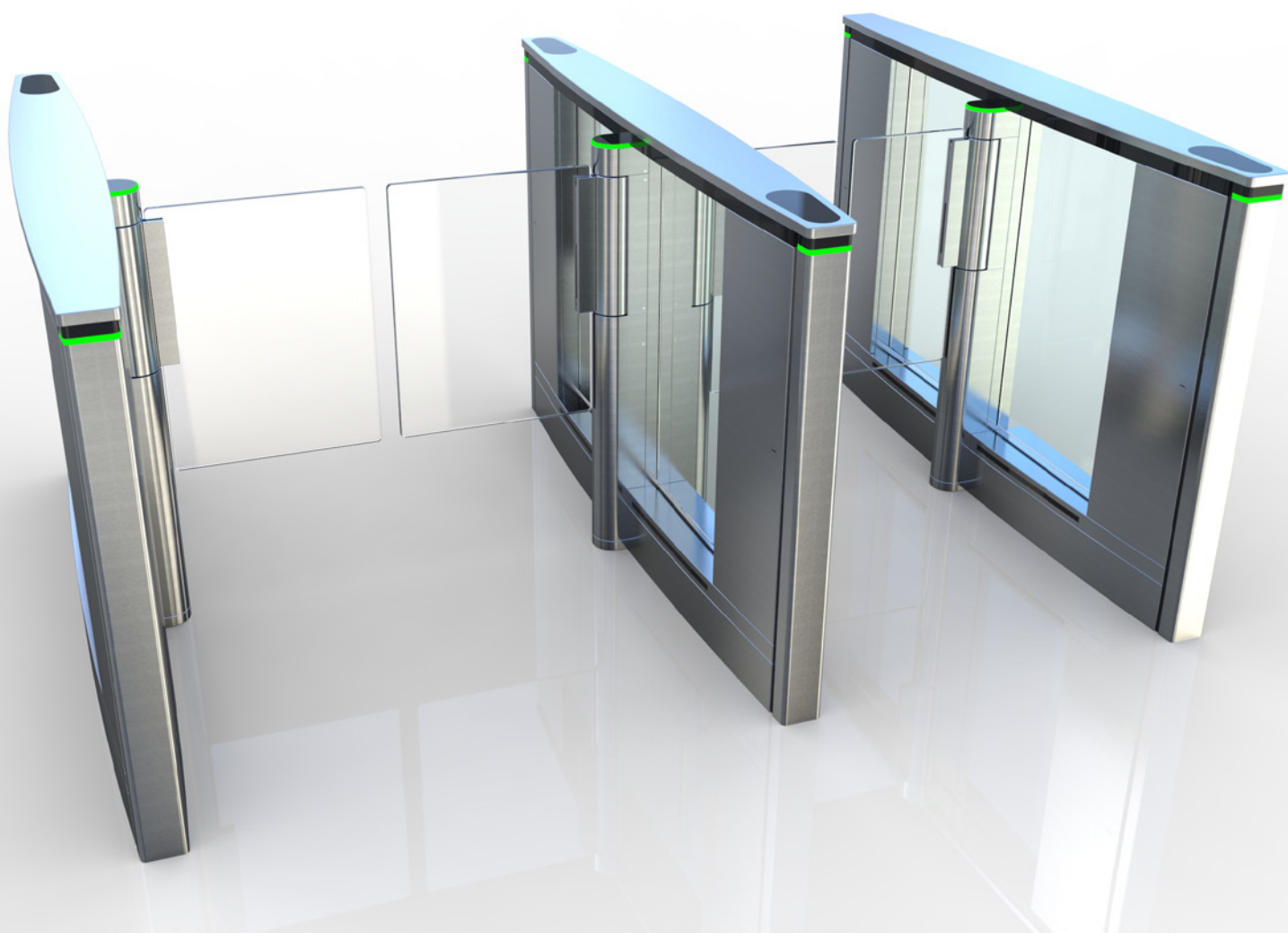

PG300 - SWING GATE



Pedestrian Speed Gates provide a fast, dynamic and secure way to manage your access control. The swing-door gates are made of a safe transparent tempered glass with a slim design and are available in a range of optional glass heights and lane widths. They are easy to fit in any installation environment and are suitable for any building where there is a need to control and manage the flow of pedestrians with the added benefit of enhancing the image of your business.

FEATURES

- Bi-directional gates
- Optional speed settings
- Auto-locking when no signal is received
- Anti-collision function: maximum 120Nm force crash resistance
- Optional 9 different bi-directional work modes
- Manual gate release for unlocking in the event of power failures
- Auto-reset function
- Timing function to set different access times

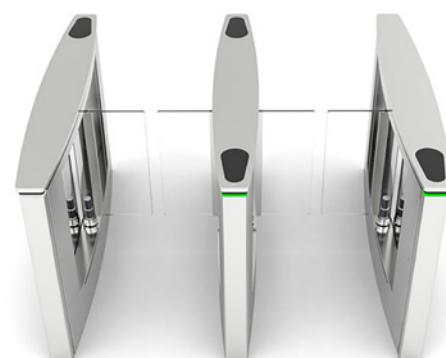

TECHNICAL SPECIFICATIONS

Model no.	SPG300
Control mode	Relay input
Serial interface	RS232/485
I/O	Input: v1/RS232 Output counter
MTBF	3,000,000 times
Lifetime	5,000,000 times
Passing frequency	30-45 people/ minute
Power	AC220v 50/60Hz
Consumption	<100W
Temperature	-20°C to 70°C
Humidity	<95%
Aisle width	600-900mm
Glass material	10mm plexiglass 8mm tempered glass
Cabinet material	AISI304 2.0/1.5mm
Size	1600mm x 980mm x 100mm
Weight	62 kg per column unit

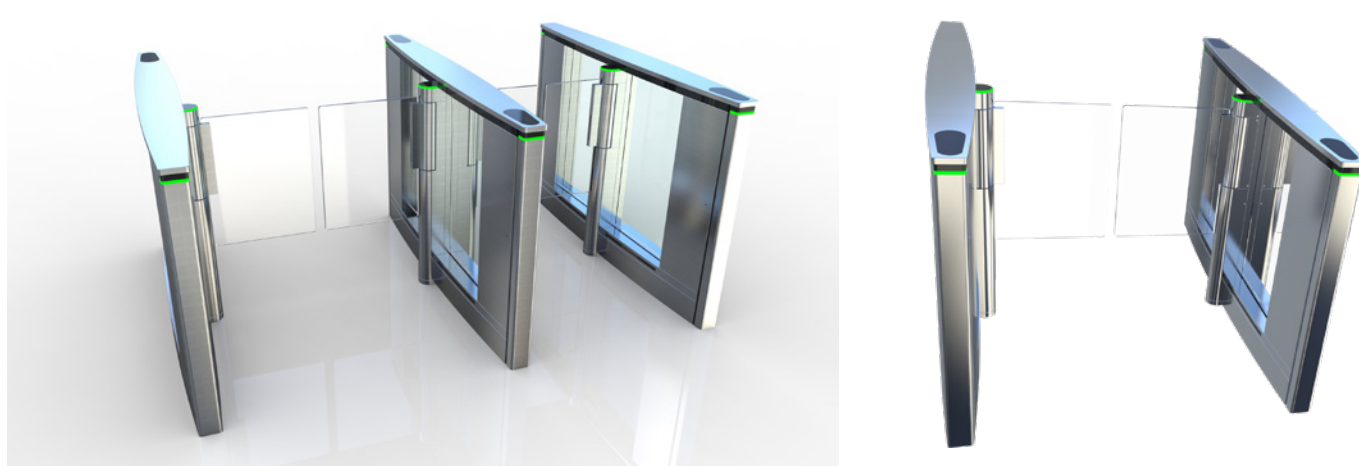

A full range of Pedestrian Speed Gates are available from BFT Automation.
For more information, please contact us at: info.uk@bft-automation.com

SGR - SWING GATE

The SGR is a secure and safe swing gate which has been specifically designed to offer a cost-effective alternative to other speed gates typically used in controlling access to gyms, education and office environments.

The Swing Gate SGR 900 features a 900mm clear walkway and can be used in a configuration to meet: fire regulations, requirements for people with reduced mobility and accommodate large bulky items.

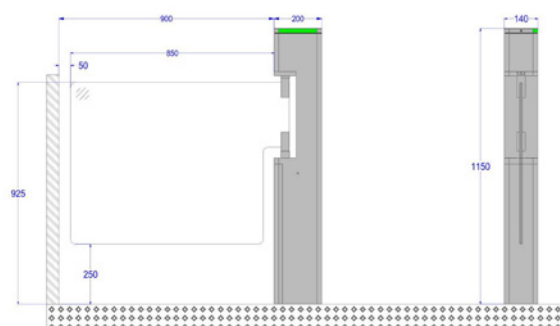

FEATURES

- Passage Width: 900mm single unit, master slave 1750mm
- 6 Detection Sensors. 3 high A+B+M and 3 low A+B+M
- Status and functional LED's: Indicating fraud, lane and passage status to the user
- Control mode: 9 operating modes, controlled, free, barred
- MCBF of 5 million cycles, with regular maintenance
- Extended manufactures parts warranty for low cost of ownership
- 10~20 people per/min. Depending on access control
- Photocell for all users provide protection during the opening and closing cycle
- Low impact force in the opening and closing cycle
- In the event of a power loss, the obstacles can be manual push in any direction
- Installation should follow BS7036 guidance

Model no.	SGR
Mains voltage	Switchable 100 to 240 Vac
Frequency	50/60Hz
Working voltage	24Vdc
Current	Static 300mA, dynamic 3A
Operating temperature	-20°C to 60°C
Storage temperature	-40°C to 60°C
Relative Humidity	5% to 95 % no condensation

The SGR can be used as a single or double cabinet with a configuration providing a large opening with high speed and bi-directional pedestrian throughput. LED status and functional lighting provide clear route indicators for users.

The SGR gate can be controlled from a variety of devices, such as a simple push button through to an access control management system with ID cards, facial recognition and QR codes etc.

For additional safety the SGR gate can be connected to the fire alarm system to automatically open on activation and on power failure. It can be manually pushed open in either direction.

There are four standard arms sizes, with custom options available:

- 630mm clear opening, trombone arm
- 920mm clear opening, trombone arm
- 600mm clear opening, full panel
- 900mm clear opening, full panel

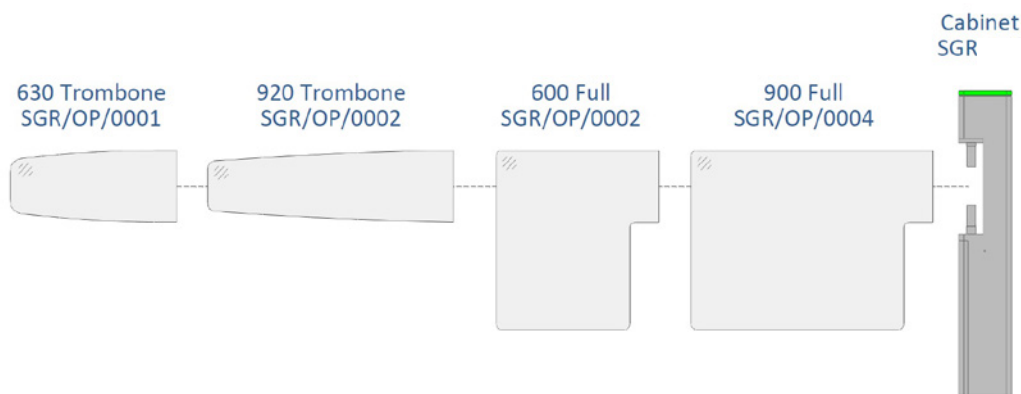

Six diffuse-reflective photocells are supplied as standard, the three high level photocells:

- Monitor the user passage
- Detects loitering, tailgating and wrong direction of travel
- Provide safety during the opening and closing cycle

The three low level photocells provide the same functions as the high level sensors but for users less than 0.9m in height, making the SGR one of the most secure and safest swing gate on the market.

SECURITY

- Photocells allow the gate to close after a passage, reducing security breaches such as tailgating and collusion
- Low gap under optically only 180mm
- Obstacle height to 925mm from FFL
- Obstacle material is plexiglass which increases the resistance to attacks by hammers
- Electromechanical locking brake to withstand forced entry attempts
- Fire alarm input enables immediate opening of the gate
- Place of use: Indoors only
- Open Commands: Normally open volt free contacts, closing for not more than 1 second
- Hold open: Normally open volt free contacts, closing for more than 3 seconds
- Fire Input: Normally open volt free contacts, closing for more than 3 seconds
- Outputs: Three transistor outputs, two for passage complete or counters and one for fraud alarms
- Output: RS232 protocol

SG100 - SWING GATE

The SG100 series of swing gates complements our range of entrance gates and turnstiles, providing emergency exit whilst allowing access for people with reduced mobility and large bulky items.

The SG100 can be used alone or as a master/slave system and in conjunction with our PG, RT or TT pedestrian entrance control products.

FEATURES

- Large passage widths
- Plexi-glass or toughened glass leafs
- Leaf height up to 1.5 metres
- Optional detection sensor for increased security and safety

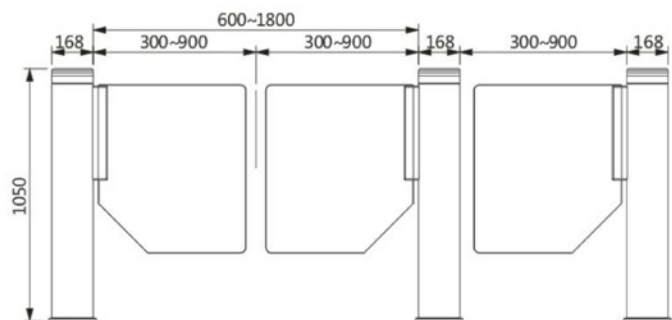
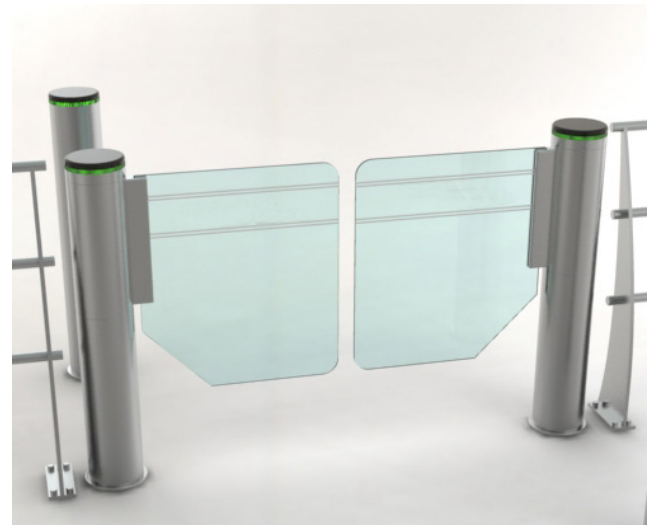

Model no.	SG100
Operating modes	9 modes, any combination of Controlled, Free, Barred
Opening speed	0.8 to 1.2 seconds depending on obstacle width.
Stacking function	Can remember 1 to 99 open commands
Column material	1.5 mm ASI 304 Brushed finish stainless steel
Column size	Dia, 168mm x h 1050mm
Obstacle material	10mm Plexi-glass or 8mm toughened glass
Power supply	110 or 220 Vac, 1.5 Amps, 50/60 Hz
MCBF (100 duty cycle with maintenance)	Minimum 1 million operations open/close
Operating Temperature	-20°C to 60°C
Relative Humidity	5% to 95 %.
Environment	Internal use only

TT300 - TURNSTILE

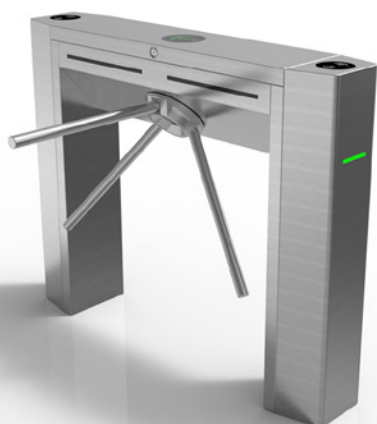

The TT300 modular design tripod turnstile offers, cost-effective, fast operating, easy to use, reliable entrance solution for internal or external use in areas where there is a large and constant flow of people.

The turnstiles are designed for use in metro stations, railway stations, bus stations, airports, corporate reception areas, factories, hotels, scenic spots, museums, libraries, exhibition centres, stadiums, education facilities and cinema, etc.

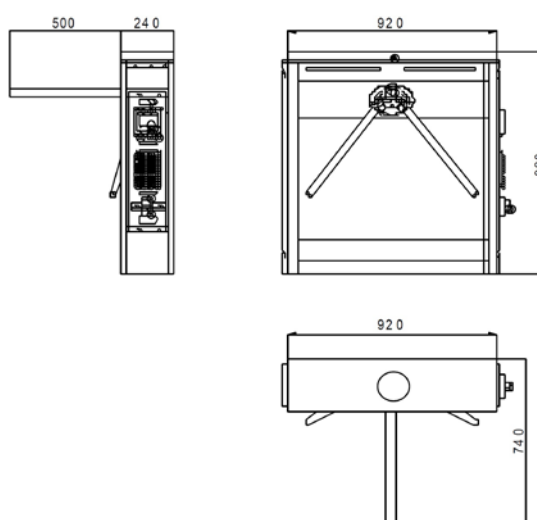

Model no.	TT300
Electrical supply	Single phase, 110-240 Vac (+/-10%), 120W 50/60 Hz
Operating voltage	24V DC
Power consumption	Standby: 5W, Cycle: 35W, Peak: 40W
Ambient operating temperature	-20°C to +60°C
Ambient relative humidity	< 95%, no condensation
Average life span	Not less than 5,000,000 cycles, with recommended maintenance
Environment	Internal or External
Passage speed	20-30 per/minute, dependent on access control and user types
Passage width	550mm
Safety	Power failure - drop arm, Fire input - drop arm
Cabinet material	Brushed Stainless Steel AISI#304



North Office

Units C2-C3 The Embankment
Business Park, Vale Road, Heaton
Mersey, Stockport, SK4 3GL

T. 0161 456 0456
F. 0161 456 9090
E. north.uk@bft-automation.com

South Office

Enterprise House, Murdock Road,
Dorcan, Swindon
SN3 5HY

T 01488 674 750
F 01488 674 790
E. south.uk@bft-automation.com



Be ahead